

PALLADIUM SERIES MODULAR SYSTEMS

TRUE[®]

The Palladium modular systems are a highly customizable solution that provide you the flexibility to choose the exercise stations and positioning that best suits your facility. Choose from 6 different configurations and 5 available add-on stations to create the Modular System perfectly suited for your specific needs. Further enhance your brand with personalized paint colors and upholstery.

3 MODULAR FRAMES WITH DUAL CABLE CROSSOVERS TMS12000

FEATURES

- 3x **TMS4000** 4-Sided Pods + 2x Cable Crossovers with Adjustable Cable Columns
- 2x Multi-Grip Chin Bar Assemblies with Suspension Brackets
- Cable Crossovers available with 170 lb/85 lb (77 kg/39 kg) resistance or 250 lb/125 lb (114 kg/57 kg) resistance weight stacks

STATIONS (UP TO 8)

A END STATIONS (MAX 2 / MIN 0)

- Single Adjustable Cable Column **TMS0070** | 170 lb/85 lb (77 kg/39 kg) resistance or 250 lb/125 lb (114 kg/57 kg) resistance
- Biceps Curl **TMS0600** | 170 lb (77 kg)
- Triceps Extension **TMS0500** | 170 lb (77 kg)

B SIDE STATIONS (MAX 6 / MIN 3)

- Lat Pulldown **TMS1100** | 210 lb (95 kg) or 310 lb (141 kg)
- Seated Low Row **TMS1200** | 210 lb (95 kg) or 310 lb (141 kg)



12 weight stack configuration
shown with optional front
and rear shrouds



innovativeFIT.com | 877.720.4004 | 770.218.9390

TMS12000 MODULAR SYSTEM



12 WEIGHT STACK CONFIGURATION (Fits in center of room)

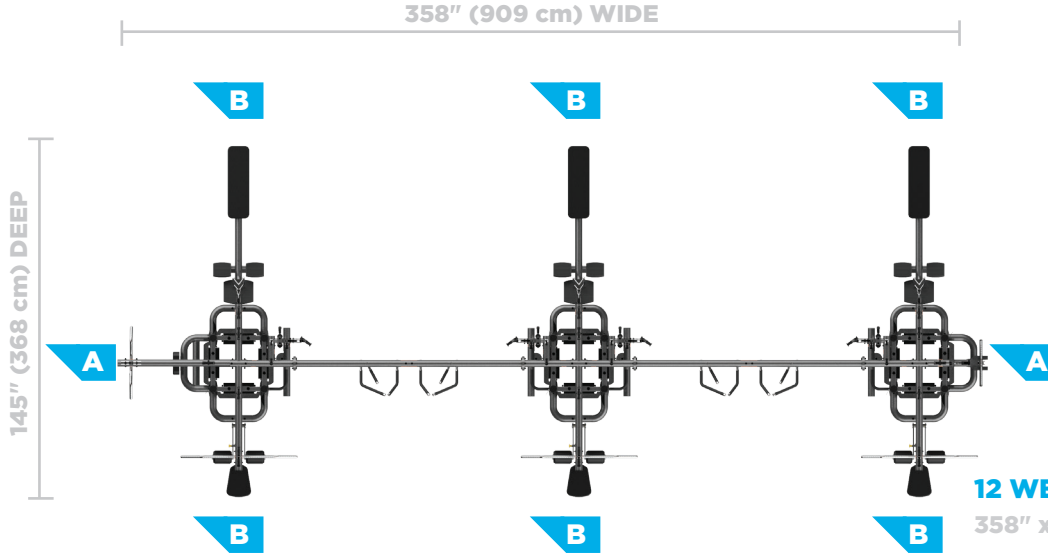

A END STATIONS
SINGLE CABLE COLUMN
BICEPS CURL
TRICEPS EXTENSION

B SIDE STATIONS
LAT PULLDOWN
SEATED LOW ROW

12 WEIGHT STACK DIMENSIONS
 358" x 145" x 96" / 909 cm x 368 cm x 243 cm

9 WEIGHT STACK DIMENSIONS
 358" x 103" x 96" / 909 cm x 262 cm x 243 cm

9 WEIGHT STACK CONFIGURATION (Fits up against mirror or wall)

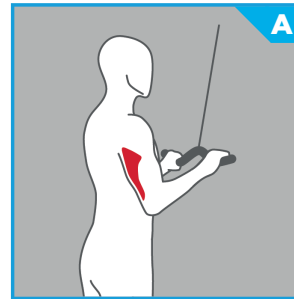
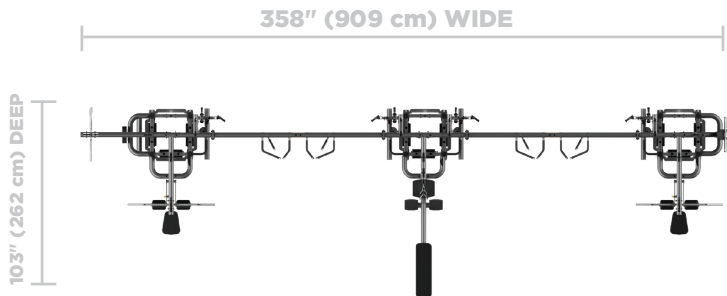

A SINGLE ADJUSTABLE CABLE COLUMN
TMS0070
 Single adjustable cable column with swivel pulley housing and easy lift handle. 25 different positions.

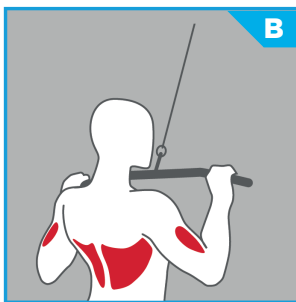

B LAT PULLDOWN
TMS1100
 Adjustable thigh pad assembly with elevated weight stack for easy access.

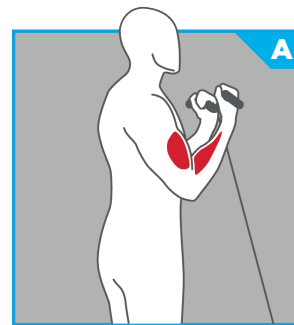

A BICEPS CURL
TMS0600
 Space efficient biceps curl station.

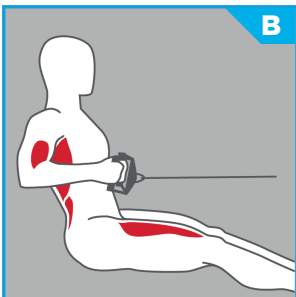

B SEATED LOW ROW
TMS1200
 Elevated seat position minimizes floor space.

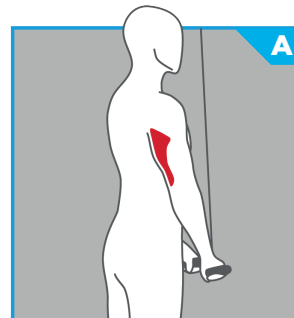

A TRICEPS EXTENSION
TMS0500
 Triceps station with comfortable upholstered back support pad.