

FLUIDPOWERPRESS

SQUAT TO OVERHEAD PRESS MACHINE

FLUID
POWER
ZONE



FluidPowerPRESS is an industrial quality, concentric action Squat to Overhead press machine. The resistance is infinitely variable via the 10x Fluid Resistance mechanism, built into every FluidPowerZone machine and the unique semi isokinetic nature of our patented Twin Tank system.

The PRESS enables you to explode with high loads at high speeds, without having to deal with the eccentric loading unavoidable with most traditional forms of resistance exercise. This built in safety feature allows both the athlete competing for peak power and the deconditioned first time participant to achieve their fitness and strength goals without intimidation or injury.

The tapered shoulder pads, ergonomic hand rails and counter balanced press arm mean all exercisers can find a comfortable, secure training position without the need to make time consuming adjustments.



OVERHEAD
PRESS



SQUAT



COLOUR OPTIONS: ORANGE GREY CUSTOM

FLUIDPOWERPRESS

PRODUCT SPECIFICATIONS

PRODUCT MODEL NO:	PZ-PRE
FLUID RESISTANCE:	Vertical FDF Twin Tank - 10 levels
PRODUCT NET WEIGHT:	94.3kg [207.9lb]
PRODUCT GROSS WEIGHT:	116kg [255.7lb]
DIMENSIONS:	L 1,710mm [57.1"] x W 830mm [32.7"] x H 2,450mm [96.5"]
MIN ACTIVE AREA REQUIRED:	L 2,150mm [94.9"] x W 1,600mm [63"]
MAX USER WEIGHT:	180kg [396.8lb]
VERTICAL SPACE:	H 2,480mm [97.6"] at full extension
PRESS ARM WEIGHT:	6kg / 13.2lb



CONSOLE FEATURES

- + Bluetooth connectivity
- + Auto start
- + Power graphs - 2 options
- + Interval training ready
- + Heart rate - Polar compatible

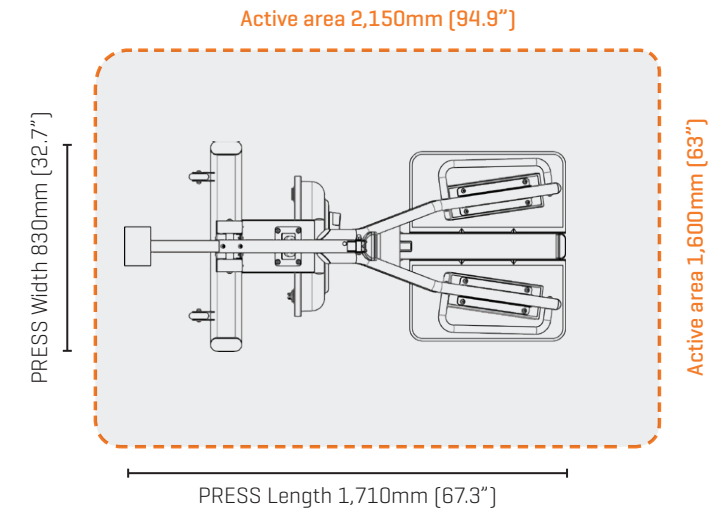

ABOUT FLUIDPOWERZONE MACHINES

FluidPowerZone is a range of fluid resistance fitness machines, designed for training in any Zone - Cardio, Power, Strength or Speed. FluidPowerZone machines can be used individually, or by combining multiple machines to make up a fitness circuit. The patented Twin Tank technology delivers 10 different levels of fluid resistance for concentric only movements that will accommodate all levels and abilities, from general fitness enthusiasts to elite athletes and provides a perfect platform for rehabilitation/medical applications.

INTERNATIONAL WARRANTY - FULL COMMERCIAL USE

- METAL FRAME - 10 year limited warranty
- MECHANICAL COMPONENTS [of a non-wearing nature] - 2 year limited warranty
- POLYCARBONATE TANK & SEALS - 5 year limited warranty
- ALL OTHER COMPONENTS - 2 year limited warranty

innovativeFIT.com | 877.720.4004 | 770.218.9390



**FLUID
POWER
ZONE**

View other FluidPowerZone machines
in the range at [FLUIDPOWERZONE.COM](https://www.fluidpowerzone.com)



CLIMB



UBE



CUBE



ROW



ERG