

FLUIDPOWERCLIMB

CONTRALATERAL FULL BODY CLIMBER

FLUID
POWER
ZONE



FluidPowerCLIMB is a high-quality commercial grade contralateral full body climber. Contralateral climbing means that the opposite arm and leg will be synchronised in a natural movement pattern allowing the spine to remain in a neutral position.

The CLIMB is designed to withstand the most vigorous HIIT workout or provide silky smooth resistance suitable for warm ups, cool downs and rehabilitation. The resistance is set via our 10x Fluid Resistance patented Twin Tank system and the climbing rate is driven by you. The CLIMB seamlessly and automatically adjusts to your step height and arm reach requirements. You control the Speed, Resistance and Range of Motion to allow you to train in any zone; Cardio, Power, Strength or Speed.

The full body CLIMB doubles up as a lower body stepper. Stepping reduces the total workload compared to climbing. The handrails can provide additional support to further reduce the load. Swapping between climbing and stepping adds another element of training variation in any zone, for any fitness level.

The FluidPowerCLIMB is a perfect inclusion for any type of fitness facility, it can add variety to all types of group and individual training and it only takes up half the space of a treadmill.



CLIMB
ACTION



STEP
ACTION



COLOUR OPTIONS: ■ ORANGE ■ GREY CUSTOM

FLUIDPOWERCLIMB

PRODUCT SPECIFICATIONS

PRODUCT MODEL NO:	PZ-CLI
FLUID RESISTANCE:	Vertical FDF Twin Tank - 10 levels
PRODUCT NET WEIGHT:	144.6kg [318.8lb]
PRODUCT GROSS WEIGHT:	171.2kg [377.4lb]
DIMENSIONS:	L 1,550mm [61"] x W 790mm [31.1"] x H 2,480mm [97.6"]
MIN ACTIVE AREA REQUIRED:	L 2,150mm [94.9"] x W 1,390mm [54.7"]
MAX USER WEIGHT:	180kg [396.8lb]
VERTICAL SPACE:	H 2,480mm [97.6"] at full extension



CONSOLE FEATURES

- + Bluetooth connectivity
- + Auto start
- + Power graphs - 2 options
- + Interval training ready
- + Heart rate - Polar compatible

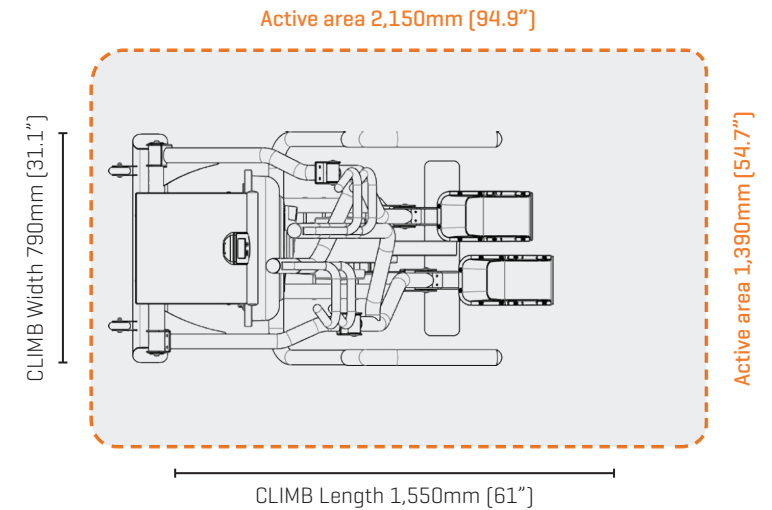

ABOUT FLUIDPOWERZONE MACHINES

FluidPowerZone is a range of fluid resistance fitness machines, designed for training in any Zone - Cardio, Power, Strength or Speed. FluidPowerZone machines can be used individually, or by combining multiple machines to make up a fitness circuit. The patented Twin Tank technology delivers 10 different levels of fluid resistance for concentric only movements that will accommodate all levels and abilities, from general fitness enthusiasts to elite athletes and provides a perfect platform for rehabilitation/medical applications.

INTERNATIONAL WARRANTY - FULL COMMERCIAL USE

- METAL FRAME - 10 year limited warranty
- MECHANICAL COMPONENTS [of a non-wearing nature] - 2 year limited warranty
- POLYCARBONATE TANK & SEALS - 5 year limited warranty
- ALL OTHER COMPONENTS - 2 year limited warranty

innovativeFIT.com | 877.720.4004 | 770.218.9390



**FLUID
POWER
ZONE**

View other FluidPowerZone machines
in the range at [FLUIDPOWERZONE.COM](https://www.fluidpowerzone.com)



PRESS

UBE

CUBE

ROW

ERG